

Programmable transmitter for thermocouple

DAT 2045

FEATURES

- Input for thermocouples type K, J, R, S and T
- Unit of measure configurable in °C or °F
- Zero and Span values configurable by DIP-switches
- 4 to 20 mA “voltage linear” output on current loop
- Good accuracy and performance stability
- EMC compliant – CE / UKCA mark
- DIN rail mounting in compliance with EN-50022 and EN-50035

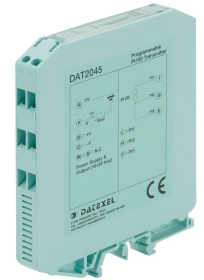

GENERAL DESCRIPTION

The transmitter DAT 2045 is designed to provide on its output a 4+20 mA current loop signal linear and proportional with the value of voltage generated from the thermocouple connected to its input.

The DAT 2045 doesn't execute the linearisation of the input signal; this feature allows to use the transmitter with acquisition systems with an internal linearisation software.

The user can program the input ranges by the proper DIP-switches available after opening the suitable door located on the side of device (see “Input range table” section).

The regulation of Zero and Span values is made by the ZERO and SPAN potentiometers located on the top of device.

It is housed in a plastic enclosure of 12.5 mm thickness suitable for DIN rail mounting in according to EN-50022 and EN-50035 standards .

OPERATIVE INSTRUCTIONS

The input connections must be made as shown in the section “Wiring”. The 4+20 mA output signal is measurable in series to the power loop as shown in the section “Power supply/output connections”; “Rload” is the input impedance value of the instruments located on the current loop; for a correct measure, it is recommended that the maximum value of “Rload” must be calculated as function of the power supply value (refer to the section “ Load characteristic ”). The configuration of input ranges values is made by DIP-switches (refer to the section “Input range table”).

After the transmitter configuration, it is necessary to calibrate it using the ZERO and SPAN regulations; this operation is illustrated in the section “DAT 2045: Configuration and calibration”. This operation can be made on field refer to a calibrated thermometer or using a simulator of thermocouple; in case of use of simulator of thermocouple with internal CJC, the value of voltage corresponding to the ambient temperature must be subtracted from the input voltage. To install the device refer to the section “Installation instructions”.

TECHNICAL SPECIFICATIONS (Typical @ 25 °C and in nominal conditions)

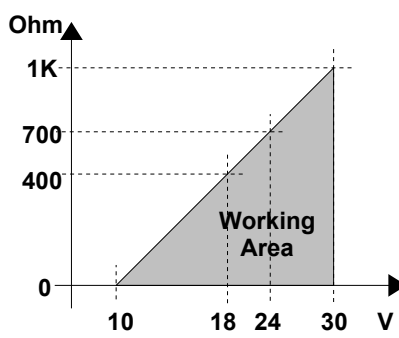
INPUT	OUTPUT	GENERAL SPECIFICATIONS
THERMOCOUPLE type J,K,R,S and T (CJC ext.) <u>Configurability for Span</u> Thermocouple “K”: from 100 to 1370 °C or from 210 to 2500 °F Thermocouple “J”: from 100 to 950 °C or from 210 to 1740 °F Thermocouple “R”: from 700 to 1760 °C or from 1200 to 3200 °F Thermocouple “S”: from 700 to 1760 °C or from 1290 to 3200 °F Thermocouple “T”: from 100 to 450 °C or from 210 to 840 °F <u>Configurability for Zero</u> programmable from -50 to 50 °C or from - 58 to 122 °F Input calibration (1) TC the higher of $\pm 0.1\%$ f.s. And $\pm 0.2^\circ\text{C}$ Input impedance TC $\geq 10 \text{ M}\Omega$ Linearity (2) TC $\pm 0.05\%$ f.s. Line resistance influence (1) TC $0.2 \mu\text{V} / \Omega$ CJC Comp. $\pm 0.5^\circ\text{C}$	Output type Current 4+20 mA two wires Thermal drift (1) Full Scale $\pm 0.02\%$ of full scale / °C (per Span > 300 °C / 500 °F) CJC $\pm 0.01\%$ / °C Out of scale values Type positive (> 20 mA) Maximum value 30 mA Response time (10÷ 90%) 500 ms circa Warm-up time 3 minutes Load characteristic - Rload (maximum load value on current loop per power supply value) 	Power supply voltage 10 .. 30 Vdc Reverse polarity protection 60 Vdc max ENVIRONMENTAL CONDITIONS Operative temperature $-20^\circ\text{C} .. +70^\circ\text{C}$ Storage temperature $-40^\circ\text{C} .. +85^\circ\text{C}$ Humidity (not condensing) 0 .. 90 % Maximum Altitude 2000 m slm Installation Indoor Category of Installation II Pollution Degree 2 MECHANICAL SPECIFICATIONS Material Self-extinguish plastic IP Code IP20 Wiring wires with diameter $0.8 \pm 2.1 \text{ mm}^2$ AWG 14-18 Tightening Torque 0.8 N m Mounting in compliance with DIN rail standard EN-50022 and EN-50035 Weight about 90 g. CERTIFICATIONS EMC (for the Industrial Environments) Immunity EN 61000-6-2 Emission EN 61000-6-4 UKCA (ref S.I. 2016 N°1091) Immunity BS EN 61000-6-2 Emission BS EN 61000-6-4

(1)referred to input Span (difference between Val. max. and min.)
 (2)inclusive of hysteresis and variations of power supply voltage

DAT 2045: CONFIGURATION & CALIBRATION

- 1) Calculate the difference between the maximum and the minimum value of the input range (Span).
- 2) Refer to the "Input ranges table", find the thermocouple in use and determine in the column "PROG SPAN" where the calculated value is included. Determine in the column "PROG ZERO", the range of value where the zero scale value is included. In the side, is shown the relative DIP-switches configuration.
In the correspondent lines is shown as to set the DIP-switches .
- 3) Set the DIP-switches as indicated .
- 4) Connect on input a simulator of thermocouple.
- 5) Set the simulator at the minimum temperature.
- 6) By the ZERO potentiometer calibrate the output at 4 mA .
- 7) Set the simulator at the maximum temperature.
- 8) By the SPAN potentiometer calibrate the output at 20 mA .
- 9) Repeat the operation from the step 5 to the step 8 until the output value will be correct (3 attempts typically required).

Configuration ex. : 0/400 °C Tc "K"

Span => 400°C;

Input switches configuration (DSI) : On, On, On, On.

INPUT RANGES TABLE

THERMOCOUPLE K PROG. SPAN	SWITCH			THERMOCOUPLE K PROG. ZERO	SW 4
	1	2	3		
100÷150°C (210÷300 °F)	●	●		- 50 ÷ - 10°C (-58 ÷ 14 °F)	
150÷470°C (300÷870 °F)	●	●	●	-10 ÷ 50 °C (14 ÷ 122 °F)	●
470÷1370°C (870÷2500 °F)	●		●		

THERMOCOUPLE J PROG. SPAN	SWITCH			THERMOCOUPLE J PROG. ZERO	SW 4
	1	2	3		
100÷150°C (210÷300 °F)		●	●	- 50 ÷ - 10°C (-58 ÷ 14 °F)	
150÷350°C (300÷660 °F)		●	●	-10 ÷ 50 °C (14 ÷ 122 °F)	●
350÷600°C (660÷1110 °F)		●	●		
600÷950°C (1110÷1740 °F)			●		

THERMOCOUPLE R PROG. SPAN	SWITCH			
	1	2	3	4
700÷800°C (1290÷1470 °F)		●		●
800÷1760°C (1470÷3200 °F)		●	●	●

The programming of the Zero is not necessary; it can be adjusted from -50 up to 50 °C by the Zero potentiometer.

THERMOCOUPLE S PROG. SPAN	SWITCH			
	1	2	3	4
700÷800°C (1290÷1470 °F)		●		●
800÷1760°C (1470÷3200 °F)		●	●	●

The programming of the Zero is not necessary; it can be adjusted from -50 up to 50 °C by the Zero potentiometer.

THERMOCOUPLE T PROG. SPAN	SWITCH			
	1	2	3	4
100÷130°C (210÷260 °F)		●		●
130÷450°C (260÷840 °F)		●	●	●

The programming of the Zero is not necessary; it can be adjusted from -50 up to 50 °C by the Zero potentiometer.

● = DIP SWITCHES: " ON"

INSTALLATION INSTRUCTIONS

The device DAT 2045 is suitable for DIN rail mounting.

It is necessary to install the device in a place without vibrations .
Moreover, it is recommended to use shielded cable to connect signals and to avoid routing conductors near power signal cables.

WIRING

INPUT CONNECTIONS

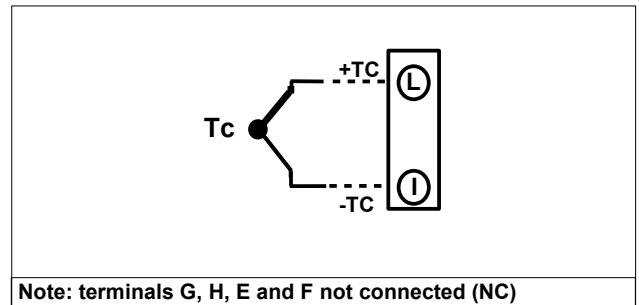

POWER SUPPLY/OUTPUT CONNECTIONS

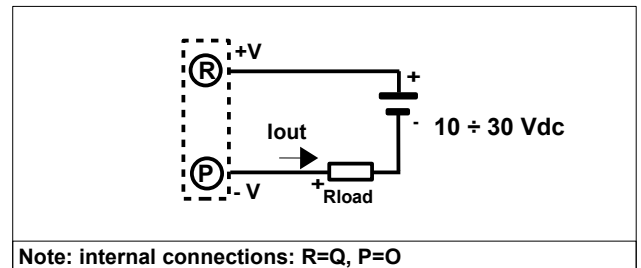

Terminals N and M are not connected (NC) .

DIMENSIONS (mm) & SETTINGS

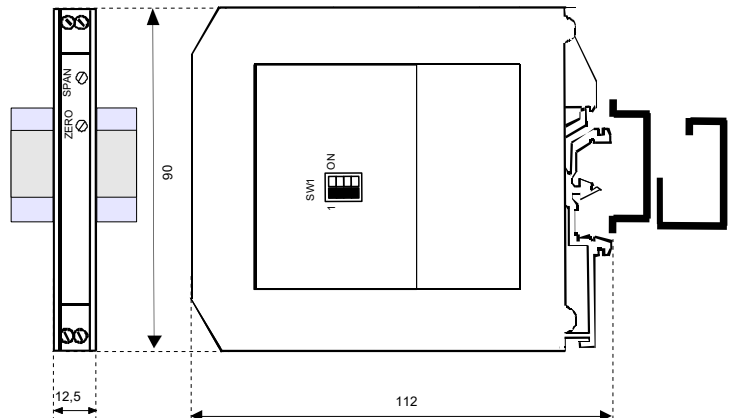

HOW TO ORDER

The DAT 2045 is supplied regulated as requested on the order.
In case of the configuration is not specified, the parameters must be set by the user.

ORDER CODE EXAMPLE: DAT 2045 - **K** - **0÷1200** **°C**



The symbol reported on the product indicates that the product itself must not be considered as a domestic waste.
It must be brought to the authorized recycle plant for the recycling of electrical and electronic waste.
For more information contact the proper office in the user's city , the service for the waste treatment or the supplier from which the product has been purchased.